

PRODUCT NO.

10033854-*52**

REVISIONS

REV	DESCRIPTION	ECN	BY	DATE
1	SKETCHED		M.H	8/28/03
2	REVISED		M.H	4/2/04
3	REVISED		M.H	6/29/04
A	RELEASED	JD4-04D1	M.H	11/9/04
C	RELEASED	T06-0229	R.C	10/12/05

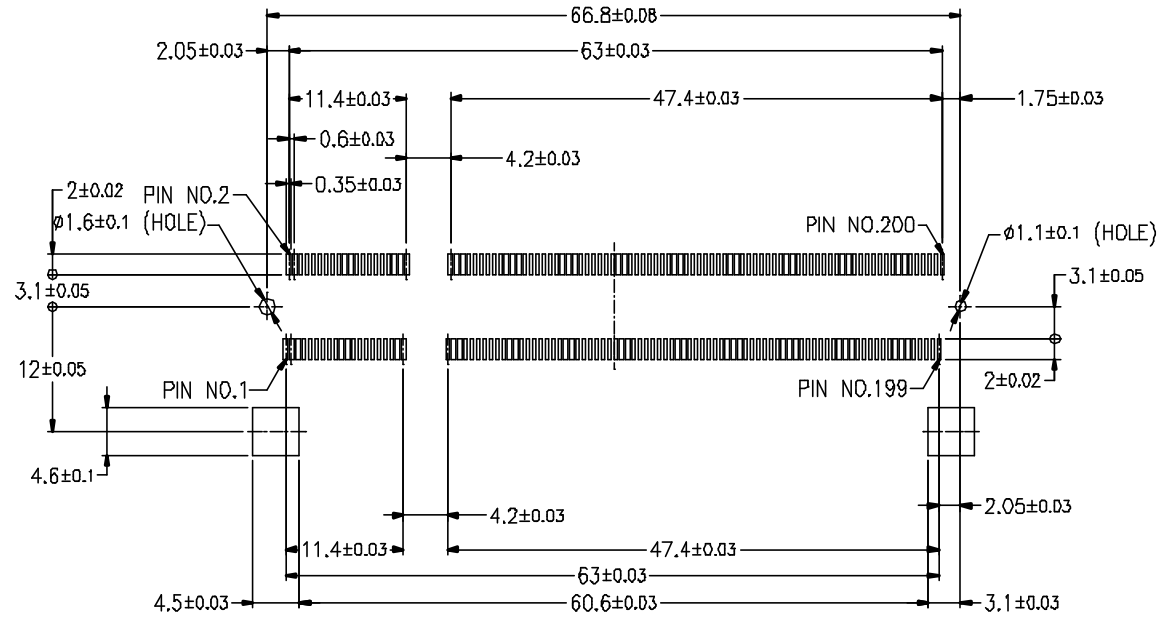

RECOMMENDED MOUNTING P.C.B LAYOUT



SHEET INDEX	ISSUE SH NO.											TITLE		PRODUCT FAMILY		CODE JP
												DDR II 0.6 mm PITCH 200 POS. REVERSE TYPE ASS'Y		50UF SO-DIMM		JP
TOLERANCES UNLESS OTHERWISE SPECIFIED		MAT		DR	DATE	CUSTOMER COPY		THIRD ANGLE PROJ		SCALE	SIZE	DWG. NO.	REV	SHEET		
±0.3		—//—		M.Hasegawa	8/28/03	COPY		⊕		2/1	B	10033854	C	20F		
LINEAR		FINISH		ENGR												
		—//—		M.Hasegawa	8/29/04											
ANGLES				CHK												
				APPD												
				UNIT												
				MM												
				INCH												

DO NOT SCALE PRINT THIS INFORMATION IS CONFIDENTIAL AND IS DISCLOSED TO YOU ON CONDITION THAT NO FURTHER DISCLOSURE IS MADE BY YOU TO OTHER THAN FCI PERSONNEL WITHOUT WRITTEN AUTHORIZATION FROM FCI JAPAN K.K.

DF-004A REV F

PRODUCT NO.

10033854-*52**

REVISIONS

REV	DESCRIPTION	ECN	BY	DATE
1	SKETCHED		M.H	8/28/'03
2	REVISED		M.H	4/2/'04
3	REVISED		M.H	6/29/'04
A	RELEASED	J04-0401	M.H	11/9/'04

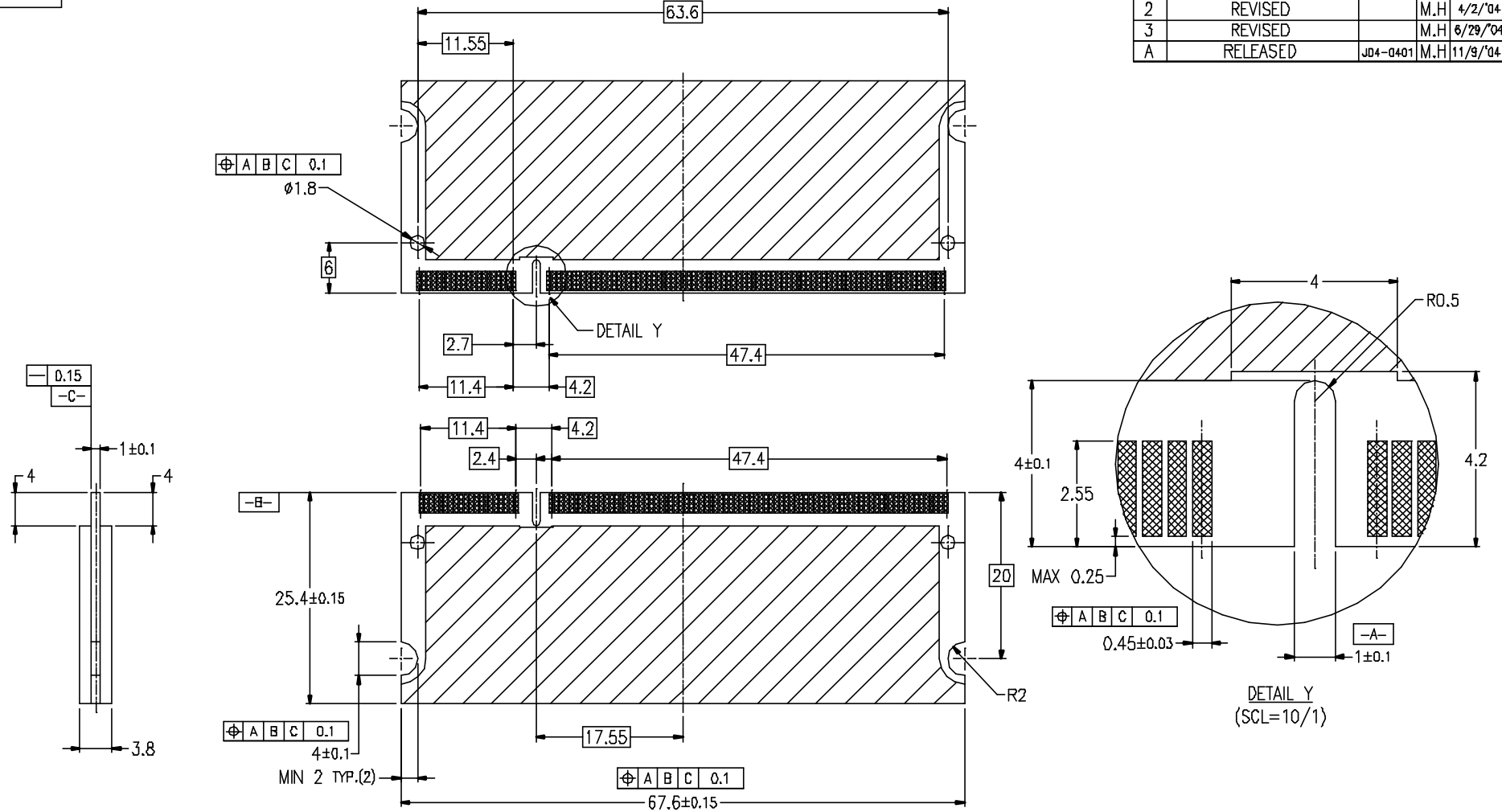

RECOMMENDED MODULE P.C.B LAYOUT

SHEET INDEX	ISSUE		MAT	DR	DATE	CUSTOMER COPY	TITLE	PRODUCT FAMILY	CODE JP
	SH NO.								
	TOLERANCES UNLESS OTHERWISE SPECIFIED		—H—	M.Hasegawa	4/29/04		DDR SO-DIMM 0.6 mm PITCH 200 POS. REVERSE TYPE ASS'Y	50UF SO-DIMM	
LINEAR	±0.3		FINISH	ENGR	4/29/04	THIRD ANGLE PROJ	SCALE	SIZE	DWG. NO.
ANGLES	±2°		—H—	CHK		UNIT	2/1	B	10033854
				APPD					REV
									A
									3of

A
FCI

TITLE: DDR SO-DIMM 0.6 mm PITCH 200 POS. REVERSE TYPE ASS'Y

PRODUCT FAMILY: 50UF SO-DIMM

SCALE: 2/1 SIZE: B DWG. NO.: 10033854

REV: A SHEET: 3of

DO NOT SCALE PRINT THIS INFORMATION IS CONFIDENTIAL AND IS DISCLOSED TO YOU ON CONDITION THAT NO FURTHER DISCLOSURE IS MADE BY YOU TO OTHER THAN FCI PERSONNEL WITHOUT WRITTEN AUTHORIZATION FROM FCI JAPAN K.K.

REVISIONS				
REV	DESCRIPTION	ECN	BY	DATE
1	SKETCHED		M.H	6/29/04
A	RELEASED	J04-0401	M.H	11/9/04
B	RELEASED	T05-0022	R.C	01/27/05

PRODUCT NO.	LOCATING PEG	TERMINAL CONTACT AREA FINISH	HOLD DOWN FINISH	SOLDER TAIL FINISH
10033854-052FSLF	YES	Au FLASH	PURE Sn PLATING	Au FLASH
10033854-152FSLF	NO			
10033854-052TSLF	YES	Au 0.3um MIN.		
10033854-152TSLF	NO			
10033854-052ASLF	YES	Au 0.76um MIN.		
10033854-152ASLF	NO			
10033854-052FB	YES	Au FLASH	Sn-Pb PLATING	
10033854-152FB	NO			
10033854-052TB	YES	Au 0.3um MIN.		
10033854-152TB	NO			
10033854-052AB	YES	Au 0.76um MIN.		
10033853-152AB	NO			
10033854-252FSLF	YES	Au FLASH	PURE Sn PLATING	Pure Sn PLATING
10033854-352FSLF	NO			
10033854-252TSLF	YES	Au 0.3um MIN.		
10033854-352TSLF	NO			
10033854-252ASLF	YES	Au 0.76um MIN.		
10033854-352ASLF	NO			
10033854-252FB	YES	Au FLASH	Sn-Pb PLATING	
10033854-352FB	NO			
10033854-252TB	YES	Au 0.3um MIN.		
10033854-352TB	NO			
10033854-252AB	YES	Au 0.76um MIN.		
10033854-352AB	NO			
10033854-452FS	YES	Au FLASH	PURE Sn PLATING	Sn-Pb PLATING
10033854-552FS	NO			
10033854-452TS	YES	Au 0.3um MIN.		
10033854-552TS	NO			
10033854-452AS	YES	Au 0.76um MIN.		
10033854-552AS	NO			
10033854-452FB	YES	Au FLASH	Sn-Pb PLATING	
10033854-552FB	NO			
10033854-452TB	YES	Au 0.3um MIN.		
10033854-552TB	NO			
10033854-452AB	YES	Au 0.76um MIN.		
10033854-552AB	NO			

10033854-□□□□ LF

- <HOLD DOWN FINISH>
- S : Pure Sn
- B : Sn-Pb
- <CONTACT AREA FINISH>
- F : Au FLASH
- T : Au 0.3um MIN.
- A : Au 0.76um MIN.
- <TOTAL HEIGHT>
- 52 : 5.2mm
- <LOCATING PEG, SOLDER TAIL FINISH>
- 0 : YES, Au FLASH
- 1 : NO, Au FLASH
- 2 : YES, Pure Sn PLATING
- 3 : NO, Pure Sn PLATING
- 4 : YES, Sn-Pb PLATING
- 5 : NO, Sn-Pb PLATING

For Rohs OPTIONS:
 TAIL PLATING CODE MUST BE 0~3.
 HOLD DOWN PLATING CODE MUST BE "S".
 "LF" CODE IS EXIST IN THE END.
 EX: 10033854-252TSLF

FOR NOT Rohs COMPATIBLE:
 THIS "LF" CODE IS "BLANK".
 EX: 10033854-452TS

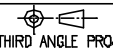

FCI

TOLERANCES UNLESS OTHERWISE SPECIFIED		MAT	DR	DATE	CUSTOMER COPY	TITLE				
±0.3		—//—	M.Hasegawa	6/29/04		DDR S0-DIMM 0.6 mm PITCH 200 POS. REVERSE TYPE ASS'Y				
LINEAR		FINISH	ENGR	6/29/04		PRODUCT FAMILY	50UF S0-DIMM			
ANGLES		—//—	CHK		THIRD ANGLE PROJ	SCALE	SIZE	DWG. NO.	REV	SHEET
±2°			APPD		UNIT	2/1	B	10033854	B	40F

DO NOT SCALE PRINT THIS INFORMATION IS CONFIDENTIAL AND IS DISCLOSED TO YOU ON CONDITION THAT NO FURTHER DISCLOSURE IS MADE BY YOU TO OTHER THAN FCI PERSONNEL WITHOUT WRITTEN AUTHORIZATION FROM FCI JAPAN K.K.